

KAPSEN



HONDA IGX800 ENGINE WITH ELECTRONIC FUEL INJECTION

ENGINE POWER 18,6 KW / 25 HP

TWO-SPEED TRAVEL WITH BRAKE

REMOTE CONTROL AUTEC

WIDE FOLDING SHIELD WITH NEW GEOMETRY



TRACKED SKIDDING MACHINE KAPSEN



KAPSEN with two-speed travel

The KAPSEN remote-controlled tracked skidding machine is designed for logging. Due to the high ground clearance and low ground pressure of the tracked chassis, it is widely used in stands with unbearable soil (peat and wetlands), but also in hilly terrain. KAPSEN is characterised by its simple operation and robust construction, which gives the machine great durability when working in forest stands.

The Honda iGX800 engine (25hp) delivers optimum performance thanks to the **STR** (self-tuning speed controller) system to ensure stable speeds under varying engine loads.

An automatic choke is integral for ease of use to reduce the problems of carburetted engines, and **electronic fuel injection (EFI)** for better fuel economy (lower running costs).

The hydromotors of the rake wheels have an integrated brake and a two-speed travel (can be shifted while driving according to the load level). The first gear is designed for pulling heavy logs, while the second gear is used to move the machine faster with lighter loads, increasing your productivity.



REMOTE CONTROL AUTEK

Working with the KAPSEN is very simple and comfortable thanks to the AUTEK remote control with a choice of modes, which can be used to control the machine travel, the winch or the folding shield with stop bath. The AUTEK remote control has the following advantages:

- **Reliability without signal failure** with greater range.
- **Excellent control** ergonomics with fine control.
- **High durability** thanks to the nylon reinforced housing, which is resistant to external influences and drops from a height.
- **Possibility of reversing** the machine travel.
- Service is provided at the customer's site within the next day.
- **M-KEY - security feature to restrict unauthorized persons from operating the radio.**



Wide folding shield with new geometry

FOLDING SHIELD

- **The new shape improves ground clearance** (higher ground clearance and improved rear approach angle).
- **The new shield geometry improves the use of maximum approach winch force and** increases the stability of the machine in difficult terrain.
- **The offset loading surface of the shield allows for higher chassis loads, improving the machine's traction capabilities** and thus increasing overall working efficiency.

KAPSEN is easy to transport in a larger van or on a trailer. If you don't own either, you can contact our sales staff for a quote for a braked trailer with a maximum load capacity of up to 1300 kg and a maximum speed of 130 km/h.



KAPSEN

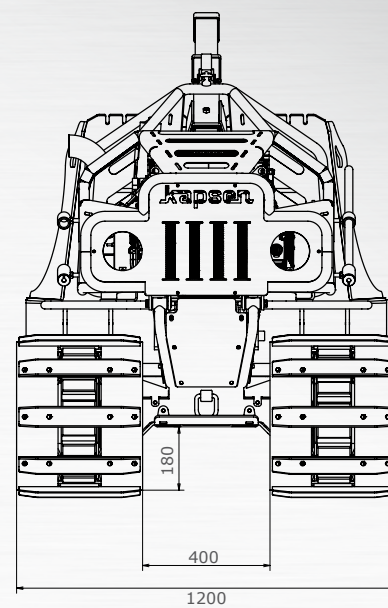
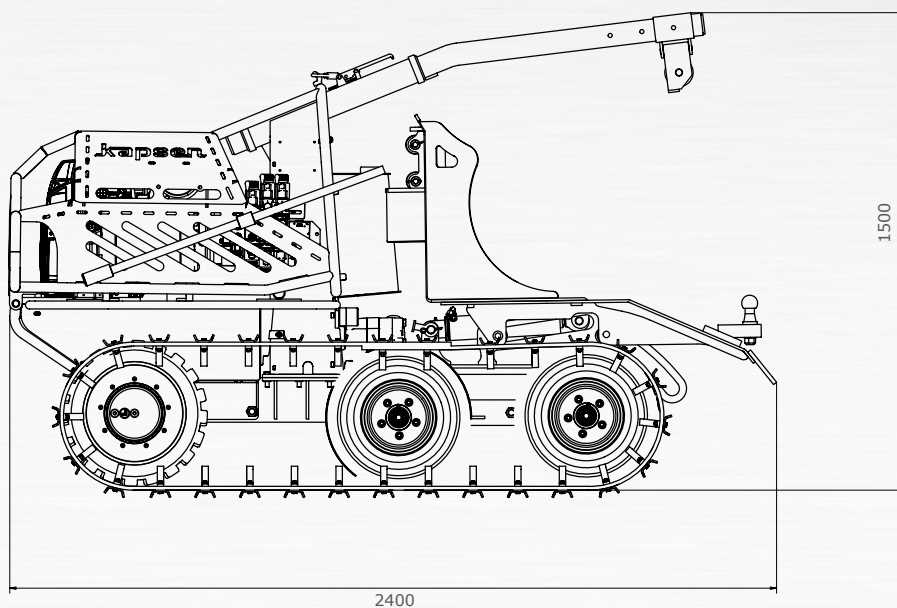

Machine dimensions are given in mm. The display may not always correspond to the standard machine design.

Specifications and equipment are subject to change.

TECHNICAL PARAMETERS

Engine type	HONDA iGX800 EFI
Engine power	18,6 kW / 25 hp
Machine speed	2,8 / 5 km/h
Winch pulling power	24 kN
Winch rope length and diameter	35 m / Ø 6 mm
Fuel tank capacity	18 l
Hydraulic system oil volume	37 l
Max. system pressure	180 bar
Belt width	400 mm
Specific ground pressure	10,4 kPa
Machine ground clearance	180 mm
Approach angles (front/rear)	65° / 33°
Dimensions in mm (l x w x h)	2400 x 1200 x 1500
Machine weight	1 230 kg

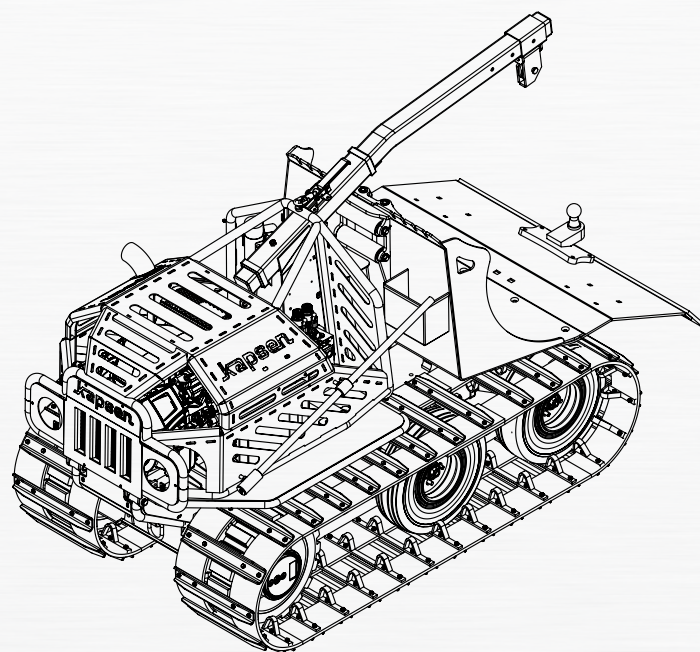

Contact for your questions, inquiries and orders:

 **+420 720 035 793**

 **info@kapsen.cz**

 **www.kapsen.cz**



2506

 www.lesni-technika.cz

 [facebook.com](https://www.facebook.com)

 [instagram.com](https://www.instagram.com)

 [youtube.com](https://www.youtube.com)

